

MobileMART

| Inspiring Solutions

MobileMART Systems Power Purchase Agreement (PPA)





PO BOX 4056-00100 NAIROBI

TEL: +254.722.254123

+254.733.254123

MobileMART Systems Power Purchase Agreement (PPA)

MobileMART Systems specializes in **hybrid smart solar solutions** and **energy management systems** to reduce electricity costs and carbon footprints.

Key features include:

1. Core Services

- **Smart Solar Solutions:** Design, installation, and management of AI-driven hybrid solar systems with battery backup, reducing power bills by 70–80% via Power Purchase Agreements (PPAs)
- **Electro Magnetic Power Generators:** Energy production on motor & Permanent Magnet monitoring/control systems saving 100% on bills using Flywheel Mechanical energy generators.
- **Hydroelectric Power:** Compact generators for sites with $\geq 8\text{m}$ water head, offering 220–415V output and automatic voltage regulation.

2. Financial Models

- **PPA/Lease-to-Own:** Institutions & businesses commercial & industrial pay no upfront costs, purchasing solar-generated power at below-grid rates over 10-15 years.
- **EPC & Maintenance:** Full-service engineering, procurement, and commissioning with warranties.

3. Additional Offerings

- **Solar Street Lights:** Modular/all-in-one LED units with MPPT controllers and lithium batteries.

- **Water Pumps & Heaters:** Solar-powered solutions for irrigation and domestic use.

The Kenya-based company also has UK corporate registration, but its primary operations focus on East Africa.

What are the benefits of using a Power Purchase Agreement (PPA) with MobileMART Systems?

Using a **Power Purchase Agreement (PPA)** with MobileMART offers several advantages tailored to businesses and institutions:

1. Cost Savings & Budget Predictability

MobileMART's PPA eliminates upfront solar installation costs, allowing clients to pay only for the solar-generated electricity they use at rates **below grid prices**. This provides **80% - 100% savings** on power bills while locking in stable energy prices for 10-15 years, shielding users from market volatility.

2. Sustainability & Net-Zero Alignment

By sourcing renewable energy through MobileMART's hybrid solar systems, organizations reduce their carbon footprint and meet **sustainability targets**, enhancing green credentials for stakeholders and customers.

3. Hassle-Free Maintenance

MobileMART owns and maintains the solar infrastructure, handling repairs and performance optimization at no additional cost to clients.

4. Scalable Energy Solutions

The PPA model accommodates energy needs as organizations grow, with flexible terms and modular solar designs.

5. Risk Mitigation

Fixed pricing under PPAs insulates clients from rising grid electricity costs and regulatory changes impacting fossil fuel-based power.

MobileMART's lease-to-own option after the PPA term further adds long-term value, enabling eventual system ownership.



What are the typical terms and conditions of a PPA with MobileMART

Typical PPA Terms with MobileMART (based on industry standards and available data)

1. Contract Duration

Likely **10-15 years** for initial agreements (as per MobileMART's lease-to-own model), with options to extend or transfer ownership afterward Industry PPAs often range from **10–20 years** for solar projects.

2. Pricing Structure

- **Below-grid rates with fixed or minimally escalated pricing** (e.g., 0.99–3% annual increases, common in solar PPAs) National grid mitigation.
- **Capacity/energy payments:** Compensation based on system output and availability.

3. Performance Guarantees

- **System availability requirements** (e.g., minimum operational uptime).
- **Liquidated damages** for underperformance or delays.

4. Payment Terms

- **Advance mobilization payments** possible (as seen in mobile plant PPAs).
- **Billing cycles:** Monthly/quarterly settlements based on energy output.

5. Risk Allocation

- **Change-in-law clauses:** Adjustments for regulatory shifts impacting costs.
- **Force majeure provisions** for unforeseen disruptions.

6. Maintenance & Ownership

- **MobileMART retains ownership** during the PPA term, handling all maintenance.
- **Performance securities:** Likely bank guarantees or letters of credit.

7. Termination Clauses

- **Early exit penalties** for buyers.
- **Guaranteed Commercial Operation Date (COD)** with damages for delays.



8. Technical Requirements

- **Interconnection standards:** Compliance with grid codes and safety protocols.
- **Metering:** High-accuracy devices (e.g., $\pm 0.2\%$ tolerance).

9. Sustainability Compliance

- **Renewable Energy Certificates (RECs):** Likely included to verify green claims.

MobileMART-Specific Conditions

- **Lease-to-own transition** after the PPA term.
- **Hybrid system flexibility:** Integration of solar, battery storage, and grid backup.

Note: Exact terms would depend on project scale and client negotiations.

What are the insurance requirements for a PPA with MobileMART

While **specific insurance requirements for MobileMART's PPAs** are not detailed in available resources, industry standards and general PPA practices suggest the following likely requirements:

1. Project Insurance (MobileMART's Responsibility)

- **Equipment Coverage:** MobileMART would typically insure solar infrastructure against damage (fire, weather, etc.)
- **Business Interruption:** Protection against revenue loss from operational downtime.
- **PPA Insurance:** Specialized coverage for energy production shortfalls, price fluctuations, or off taker default (common in solar PPAs).

2. Client-Side Protections

- **Liability Coverage:** Clients may need general liability insurance for third-party injuries/property damage on their premises.
- **Property Insurance:** If client-owned infrastructure (e.g., electrical systems) interfaces with MobileMART's equipment, proof of coverage might be required.



3. Third-Party Guarantees

1. **Performance Security:** MobileMART absorbs and might provide bank guarantees or letters of credit to ensure contractual obligations. Ability to pay checks and balances will require the following to be provided for due diligence and proof of off-taker credit check:
 1. Three years audited financial Statements
 2. Copy of valid business permit
 3. Certificate of incorporation
 4. Copy of land title deed/lease agreement
 5. Kra pin certificate
 6. Copy of IDs of company directors
 7. Cr 12
2. **Regulatory Compliance:** Both parties must adhere to local insurance laws (e.g., workers' compensation).

What are the benefits of using a Power Purchase Agreement (PPA) with MobileMART

Using a Power Purchase Agreement (PPA) with MobileMART offers several key benefits:

- **No upfront costs:** Clients avoid the high initial investment for solar system installation, paying only for the electricity generated at rates below traditional grid prices, leading to immediate savings on power bills.
- **Long-term price certainty:** The PPA fixes energy costs for the contract term (typically 10–15 – 20 years), protecting clients from volatile energy market prices and enabling easier budgeting.
- **Operational maintenance included:** MobileMART retains ownership and is responsible for system upkeep, ensuring reliable energy supply without maintenance worries for the client.
- **Reduced carbon footprint:** By using renewable solar energy, clients lower their environmental impact and support sustainability goals, enhancing their green credentials.
- **Potential lease-to-own option:** After the PPA term, clients may have the option to own the solar system, further increasing long-term value.

Overall, MobileMART's PPA model delivers cost savings, risk mitigation, sustainability benefits, and operational simplicity for businesses and institutions.



How does a PPA with MobileMART help in reducing carbon footprint

A Power Purchase Agreement (PPA) with MobileMART helps reduce carbon footprint by enabling businesses to source clean, renewable solar energy instead of relying on fossil fuel-based grid power. This substitution lowers greenhouse gas emissions associated with electricity consumption. Specifically:

- MobileMART's hybrid solar systems provide renewable energy that cuts fuel use and emissions compared to conventional power.
- By committing to purchase solar energy through a PPA, businesses directly support renewable energy generation, reducing their Scope 2 emissions (indirect emissions from purchased electricity)
- PPAs allow organizations to meet sustainability and net-zero targets by replacing carbon-intensive electricity with clean solar power, enhancing their environmental credentials.
- This approach also helps companies manage energy costs while contributing to global DE carbonization efforts.

In summary, MobileMART's PPA model facilitates significant carbon emission reductions by providing affordable, reliable access to renewable solar energy.

MobileMART Systems

MobileMART Systems is a Kenyan-based provider of green energy solutions specializing in smart solar systems for homes, businesses, and institutions. Their offerings focus on scalable photovoltaic (solar) kits and premium-quality solar components designed for efficiency, reliability, and ease of use.

Key aspects include:

- **Smart Solar Systems:** MobileMART supplies modular solar solutions, such as the MegaTank All In One Solar kit, which is designed for high performance and aesthetic integration. These systems are suitable for a range of applications, from residential to commercial, and use quality components to ensure long-term durability and optimal energy output.
- **Cost Savings:** Through advanced, AI-driven solar technology, MobileMART claims to help customers reduce electricity costs by up to 100%.
- **Sustainability:** Their solutions contribute to reducing carbon footprints by enabling access to clean, renewable solar energy.

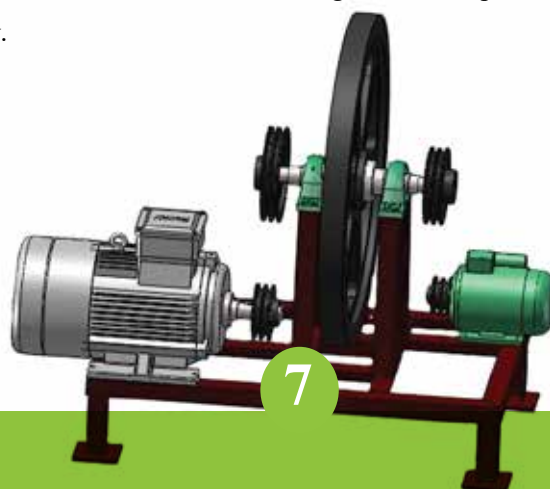

- **Flexible Financing:** MobileMART supports innovative payment models, including Power Purchase Agreements (PPAs), allowing clients to benefit from solar energy with little or no upfront investment and to pay only for the power they use.
- **Comprehensive Services:** The company covers the full spectrum of solar needs, from system design and installation to ongoing maintenance, ensuring a hassle-free transition to solar power.

MobileMART is recognized for its role in transforming East Africa’s energy landscape by making solar technology accessible, affordable, and effective for a wide range of users.

What solar solutions does MobileMART offer for off-grid energy needs

MobileMART offers a comprehensive suite of solar solutions tailored for off-grid energy needs, designed to provide reliable, efficient, and sustainable power in areas without access to the main electricity grid. Their key offerings include:

- **Hybrid Smart Solar Systems:**
MobileMART designs, supplies, installs, and commissions hybrid solar energy management systems that combine solar panels with battery storage. These systems use artificial intelligence and IoT technology to monitor, control, and optimize energy usage, ensuring power is available both during the day and at night. The smart hybrid systems are engineered for high efficiency and can significantly reduce or eliminate reliance on traditional grid power.
- **Pay-As-You-Go and Lease-to-Own Models:**
For off-grid users, MobileMART provides flexible financing options, such as Pay-Go and Lease-to-Own contracts, allowing customers to access solar power with little or no upfront cost. This makes solar energy more accessible for rural households, schools, and businesses.
- **Solar Water Pumps:**
These systems are ideal for agricultural and domestic water supply in off-grid areas. They use solar energy to power water pumps, providing a sustainable solution for irrigation and clean water access.



- **Solar Street Lighting:**

MobileMART offers modular and all-in-one solar-powered street lights with integrated lithium batteries and MPPT controllers. These are suitable for pathways, compounds, and community spaces in off-grid settings, offering reliable lighting without the need for grid connection.

- **Thermal Solar Water Heating Systems:**

Designed for off-grid homes and institutions, these systems use solar energy to provide hot water, reducing the need for electricity or fossil fuels.

- **Hydroelectric Generators:**

For locations with sufficient water resources (e.g., a water head above 8 meters), MobileMART supplies compact hydroelectric generators that can provide off-grid power independently or in combination with solar systems.

- **Comprehensive Support and Maintenance:**

MobileMART's solutions include ongoing maintenance and warranty services, ensuring long-term reliability and performance for off-grid users.

These solutions are designed to meet a wide range of off-grid energy needs, from basic household power to more complex institutional or agricultural applications, supporting energy independence, cost savings, and environmental sustainability.

**

How do MobileMART's hybrid smart solar systems optimize off-grid energy use

MobileMART's hybrid smart solar systems optimize off-grid energy use through a combination of advanced technologies and intelligent energy management. Here's how they achieve this:

- **Integrated Solar Generation and Battery Storage:**

The system uses solar panels to generate electricity during daylight hours. Excess energy not immediately consumed is stored in batteries, ensuring power availability at night or during periods of low sunlight.

- **Smart Inverter Technology:**

Hybrid inverters convert the DC electricity from solar panels into AC for immediate use and manage the charging and discharging of batteries. These inverters can operate in both off-grid (island) mode and grid-tied mode, seamlessly switching between sources to maintain a continuous energy supply.



- **Real-Time Monitoring and Control:**

The systems include monitoring platforms—accessible via control panels or smartphone apps—that track energy production, storage levels, and consumption. This real-time data allows users to optimize when and how stored energy is used, maximizing efficiency and reducing waste.

- **Battery Management System (BMS):**

An intelligent BMS monitors battery health, controls charging/discharging cycles, and extends battery lifespan by preventing overcharging or deep discharging.

- **Load Prioritization and Smart Scheduling:**

The system can prioritize critical loads and schedule high-energy tasks for times when solar generation is highest, further optimizing energy use and reducing reliance on backup generators or the grid.

- **Seamless Power Supply:**

During grid outages or in fully off-grid settings, the hybrid system draws power from the battery bank, ensuring uninterrupted electricity for essential appliances and operations.

- **Energy Independence and Cost Savings:**

By maximizing the use of self-generated solar energy and minimizing dependence on grid or generator power, users achieve greater energy independence and significant cost savings over time.

In summary, MobileMART's hybrid smart solar systems combine solar panels, advanced inverters, intelligent battery management, and real-time monitoring to deliver a reliable, efficient, and optimized off-grid energy solution.

*
**

How does the integration of batteries improve MobileMART's off-grid energy reliability?

The integration of batteries in MobileMART's off-grid solar systems significantly improves energy reliability by providing stable, continuous power even when solar generation is intermittent or unavailable. Here's how batteries enhance reliability:

- **Energy Storage for Continuous Supply:** Batteries store excess solar energy generated during the day, making it available at night or during cloudy periods, thus ensuring a steady power supply without interruptions. This eliminates reliance solely on real-time solar production, which can be variable.



- **Backup Power During Outages:** Batteries act as a reliable backup, providing power during grid outages or when solar input is insufficient, which is critical for maintaining operations in off-grid or unstable grid environments.
- **Smoothing Energy Fluctuations:** By absorbing and releasing energy as needed, batteries smooth out the variability inherent in solar power, reducing the risk of blackouts or brownouts and enhancing overall system stability.
- **Advanced Battery Management:** Intelligent Battery Management Systems (BMS) monitor charge levels, prevent overcharging or deep discharging, and optimize battery health and lifespan, ensuring consistent performance over time.
- **Facilitating Renewable Integration:** Batteries enable higher penetration of renewable energy by balancing supply and demand, which is essential for off-grid systems relying heavily on solar power.
- **Scalability and Flexibility:** Battery banks can be sized and expanded according to energy needs, allowing systems to adapt as demand grows while maintaining reliability.

In summary, batteries transform MobileMART's off-grid solar setups from intermittent power sources into dependable, resilient energy systems by storing surplus energy, providing backup power, and managing supply fluctuations intelligently.

*

**

How do batteries stabilize MobileMART's off-grid energy supply during fluctuations?

Batteries stabilize MobileMART's off-grid energy supply during fluctuations by storing excess solar energy generated during periods of high production and releasing it when solar generation is low or demand is high. This process smooths out the inherent variability of solar power, ensuring a consistent and reliable electricity supply. Specifically:

- **Balancing Supply and Demand:** Batteries store surplus energy when production exceeds consumption and discharge it when consumption exceeds production, preventing power shortages or overloads.
- **Rapid Response:** Battery systems can respond within milliseconds to changes in energy demand or supply, quickly compensating for fluctuations and preventing interruptions or voltage drops.

- **Voltage and Frequency Regulation:** Batteries help maintain stable voltage levels and grid frequency by absorbing or injecting power as needed, protecting sensitive equipment and ensuring steady power quality.
- **Backup Power:** During periods without sunlight or unexpected outages, batteries provide continuous power, enhancing reliability in off-grid settings.
- **Load Shifting:** Batteries enable shifting energy use from peak to off-peak times by storing energy when demand is low and supplying it when demand peaks, optimizing system efficiency.

Through these mechanisms, MobileMART's battery-integrated solar systems deliver a stable, resilient off-grid energy supply that maximizes renewable energy use and minimizes disruptions caused by solar variability^{[45][46][47][48]}.

*

**

How do batteries respond rapidly to fluctuations in MobileMART's energy supply?

Batteries in MobileMART's energy systems respond rapidly to fluctuations in supply and demand by leveraging their inherent ability to quickly charge or discharge electricity as needed. This rapid response is enabled by several key factors:

- **High Power Capacity and Fast Discharge Rates:** Battery Energy Storage Systems (BESS) can deliver or absorb large amounts of power almost instantaneously (within milliseconds to seconds), stabilizing the energy supply by compensating for sudden drops or spikes in solar generation or load demand.
- **Peak Shaving and Load Shifting:** Batteries store excess energy during low-demand or high-generation periods and discharge it during peak demand or low generation, smoothing out fluctuations and preventing power interruptions.
- **Advanced Battery Management Systems (BMS):** Intelligent control systems monitor real-time energy flows and battery health, optimizing charge/discharge cycles to respond immediately to changes and maintain system stability.
- **C-Rates (Charge/Discharge Speeds):** The battery's C-rate determines how quickly it can respond; high C-rate batteries (e.g., 1C) can fully discharge or charge within an hour, allowing rapid adjustment to energy supply fluctuations.

- **Grid and Off-Grid Stability:** By quickly injecting or absorbing power, batteries maintain voltage and frequency stability, protecting sensitive equipment and ensuring continuous power supply even in off-grid or unstable grid conditions.

In essence, MobileMART's batteries act as a fast-acting buffer that instantly balances energy supply and demand, ensuring a reliable and stable off-grid power system despite the intermittent nature of solar energy.

**

How quickly can MobileMART's batteries respond to supply changes

MobileMART's batteries can respond to supply changes **within milliseconds to seconds**, enabling rapid adjustment to fluctuations in solar energy generation or load demand. This fast response is typical of modern battery energy storage systems, which can instantly charge or discharge to balance supply and demand, stabilize voltage and frequency, and maintain continuous power in off-grid settings. The precise response time depends on the battery technology and battery management system used but generally occurs almost instantaneously to prevent power interruptions.

What is the typical response time of MobileMART's batteries to supply fluctuations

The search results do not provide specific information on the typical response time of MobileMART's batteries to supply fluctuations. However, based on standard industry knowledge of hybrid solar battery systems similar to those MobileMART offers, battery response times to changes in energy supply or demand typically occur within **milliseconds to a few seconds**. This rapid response enables the batteries to quickly charge or discharge, stabilizing the power supply and ensuring continuous, reliable energy in off-grid settings.

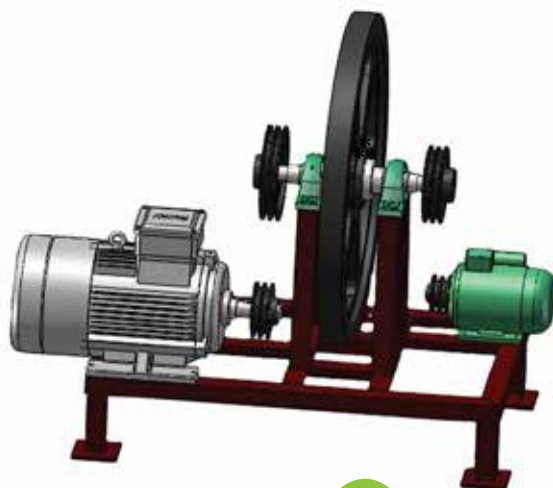

What technological features enable MobileMART's batteries to respond rapidly?

MobileMART's batteries respond rapidly to energy supply fluctuations due to several key technological features:

- **Advanced Battery Chemistry:** Use of lithium-ion or similar high-performance battery chemistries that support fast charge and discharge rates, enabling quick energy delivery or absorption.
- **High C-Rate Capability:** Batteries designed with high C-rates allow rapid charging/discharging, facilitating immediate response to changes in energy demand or supply.
- **Intelligent Battery Management System (BMS):** The BMS continuously monitors battery state-of-charge, temperature, and health, optimizing charge/discharge cycles and preventing damage while ensuring swift reaction to grid or load changes.
- **Power Electronics and Inverters:** Sophisticated inverters and power converters manage the seamless flow of electricity between solar panels, batteries, and loads, enabling instantaneous switching and energy balancing.
- **Real-Time Monitoring and Control:** Integration of IoT sensors and AI-driven control platforms allows real-time data analysis and automated adjustments, ensuring batteries respond promptly to fluctuations.
- **Modular Design:** Modular battery architecture enables scalable and flexible energy storage, allowing portions of the battery bank to activate rapidly as needed.

Together, these technologies enable MobileMART's batteries to act as fast-responding buffers that stabilize off-grid solar energy systems efficiently and reliably.

SUMMARY:

WE SUPPLY GREEN ENERGY SYSTEMS for HIGH NATIONAL GRID POWER BILLS COMMERCIAL & INDUSTRIAL PREMISES AT NO UPFRONT IMPLEMENTATION COST AND PAYABLE @50% p/m OF POWER BILLS ON CONSTANT TERMLY PPA.

MobileMART Systems Solutions Supply Install and Commission HYBRID SMART Solar & Hydro - Electric Power & Kinetic Electro Magnetic Power Systems to manage monitor control and regulate power bills. The Energy Systems save off the Power Bills on a Power Purchase Agreement (PPA). We Plan Design Implement & Manage (PDIM) and Lease to Own (LTO) Energy as a Service on Pay-Go Contractual Period with Warranty and Maintenance Services - Engineering Procurement Construction (EPC). Climate Change Mitigation | Net Zero Carbon Footprint Project | Off grid Energy Solutions.

MobileMART Systems Solutions LTD
Edwin Ranji
CEO | DIRECTOR
+254.722.254123
www.mobilemart.co.ke

The system will be full satisfaction in regard to the requirements of functionality & Performance.

System Components

- 1. Solar Panels Bi-Facial
- 2. Solar inverter Hybrid
- 3. Lithium batteries
- 4. Chargeable service: basis

Warranties

- 25 years
- 10 years
- 10 years
- (AMC) Annual Maintenance Contract is Recommended.

The system components and workmanship should not be interfered with by persons without direct involvement of Solar Works technical personnel or approved technician. This is needful to ensure that system warranties are not violated.

Upon the completion of 1-year free service, an annual service contract may be agreed upon to ensure that the system is maintained and serviced to achieve optimum performance.

ISSUED BY: INSTALLER COMPANY:

ISSUED BY: EDWIN RANJI

MOBILEMART SYSTEMS SOLUTIONS LIMITED

SIGN:



STAMP:

MobileMART SYSTEMS
SOLUTIONS.
P.O. Box 4056-00100, NAIROBI
+254 722 254 123



MobileMART Systems Power Purchase Agreement (PPA)

MobileMART

Inspiring Solutions

www.mobilemart.co.ke

Dial: +254.722.254123